

Low IQ mode quiescent current vs. Vin

NOTE: Page numbers for previous revisions may differ from page numbers in the current version.
Revision 0.8: Preliminary Specification.
Revision 0.81: Update PACKAGE INFORMATION.

ORDERABLE DEVICE	PACKAGIN G TYPE	STANDARD PACK QTY	PACKAGE MARKING	PINS	PACKAGE DESCRIPTION
---------------------	--------------------	----------------------	--------------------	------	------------------------

SCT CONF

SCTC

SCT CONFIDENTIAL



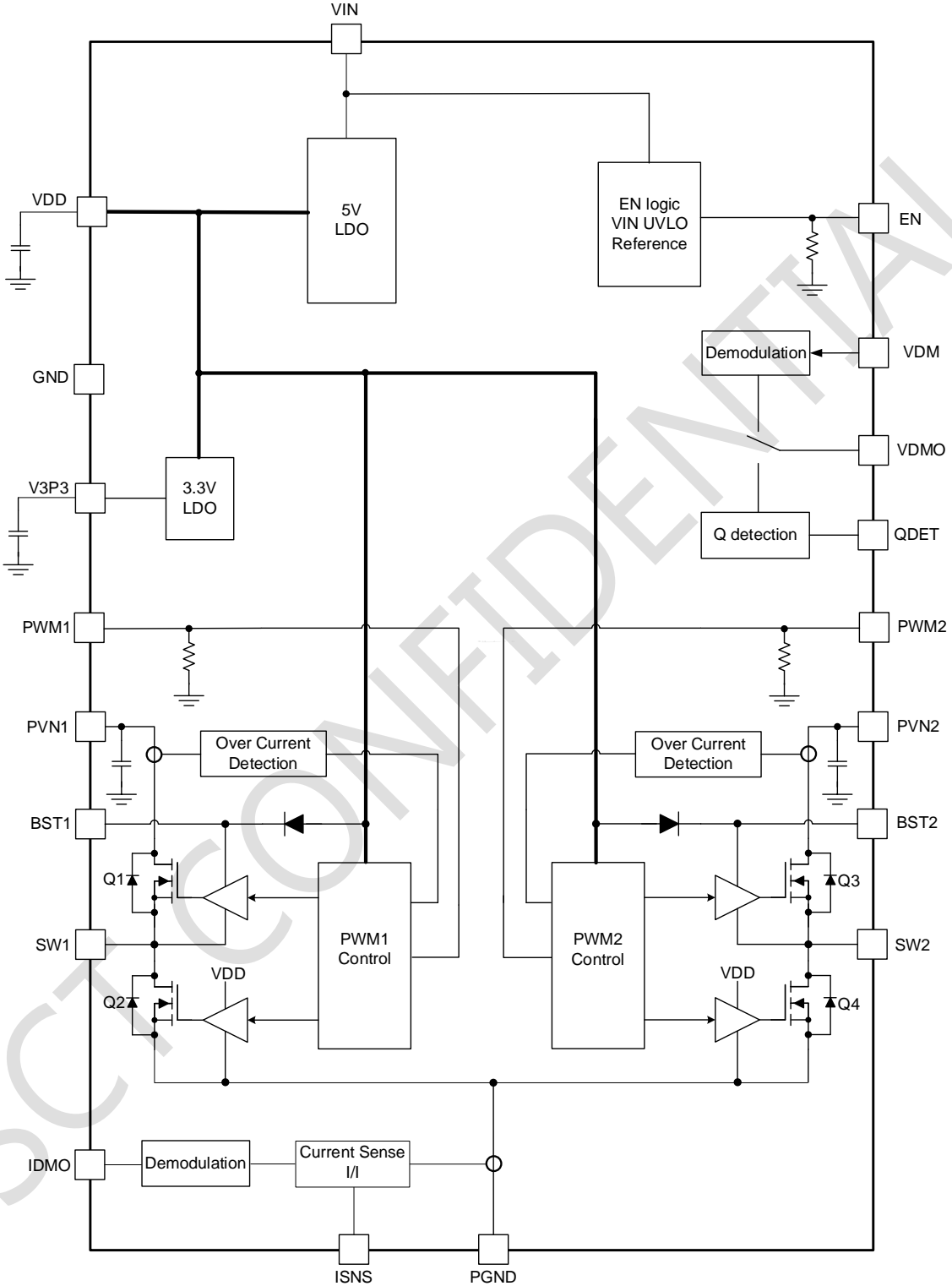

Figure 8. Functional Block Diagram

SCT CONFIDENTI

Thermal Shutdown

The SCT63152A protects the device from the damage during excessive heat and power dissipation condition. Once the junction temperature exceeds 160C, the thermal sensing circuit stops full bridge of 4-MOSFETs' working. When the junction temperature falls below 125C, then

SCT CONFIDENTIAL

SCT
CO



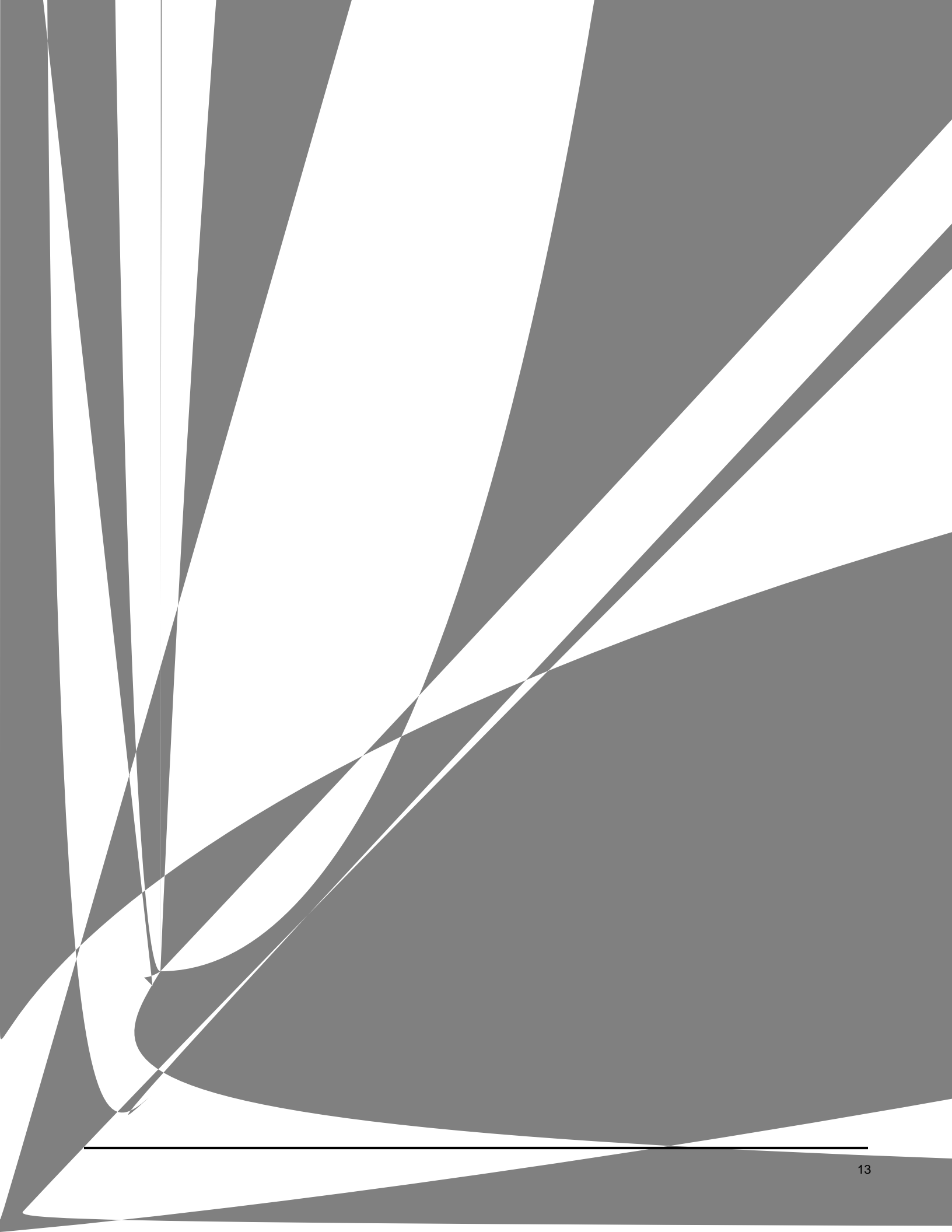

SCT CONFIDEN



SECRET