







---

---

--	--	--	--

---

--	--	--	--



---

---

---

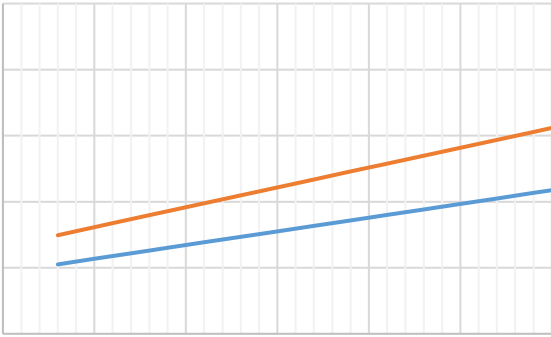

---

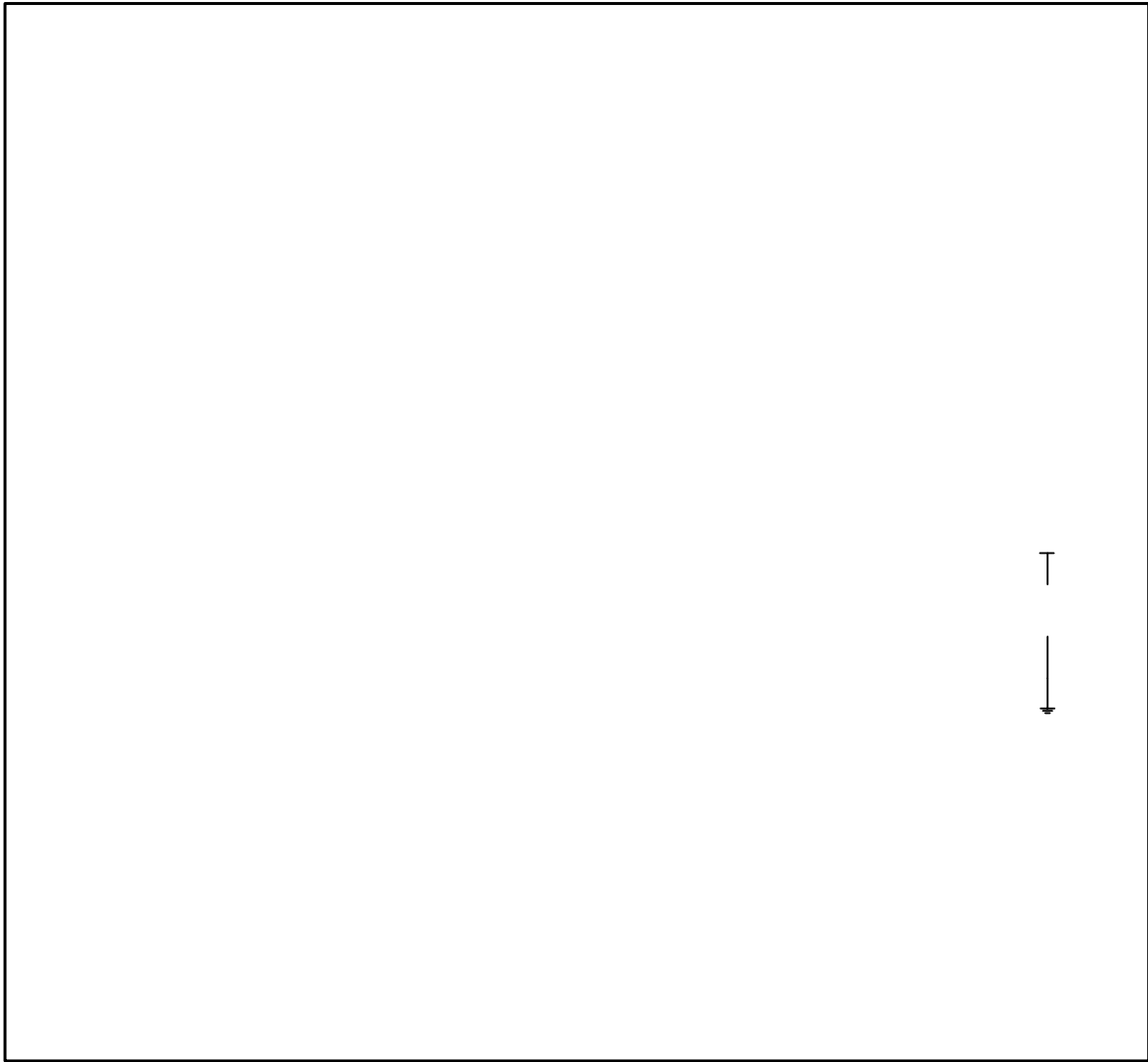

---

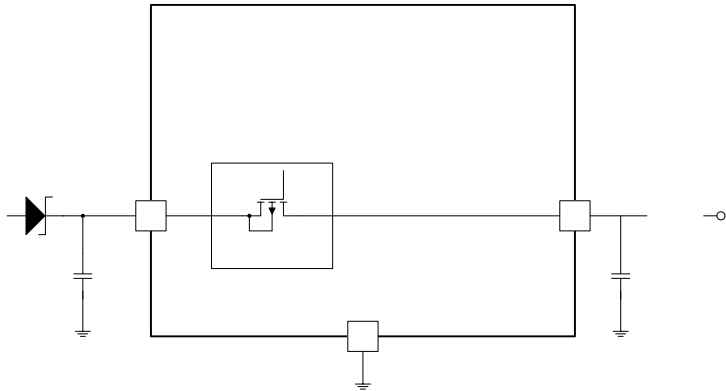



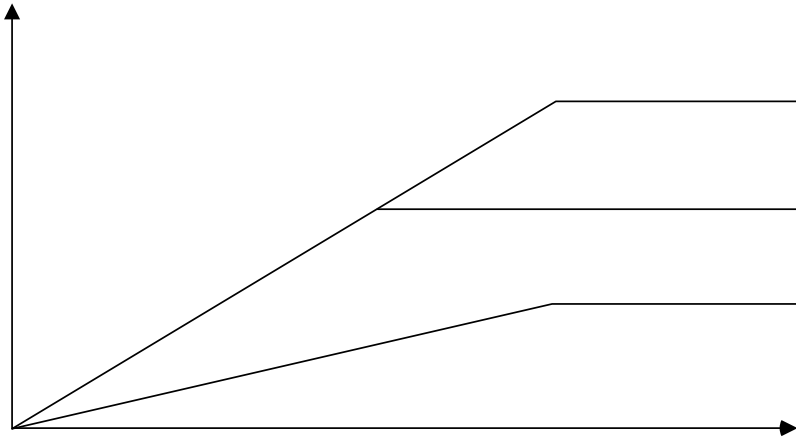
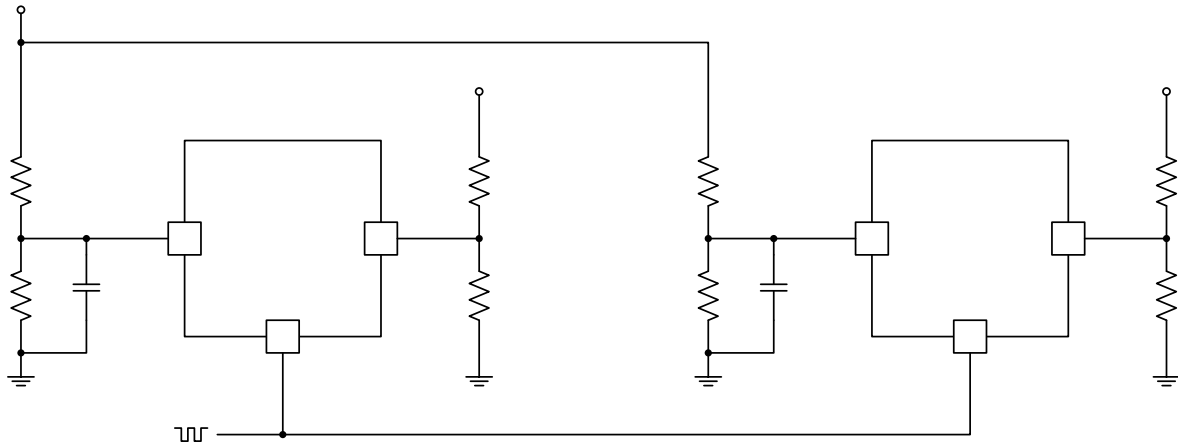





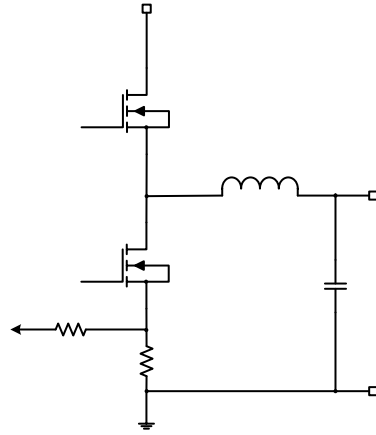
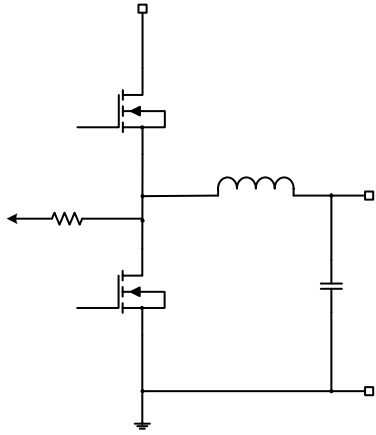

---

\_\_\_\_\_



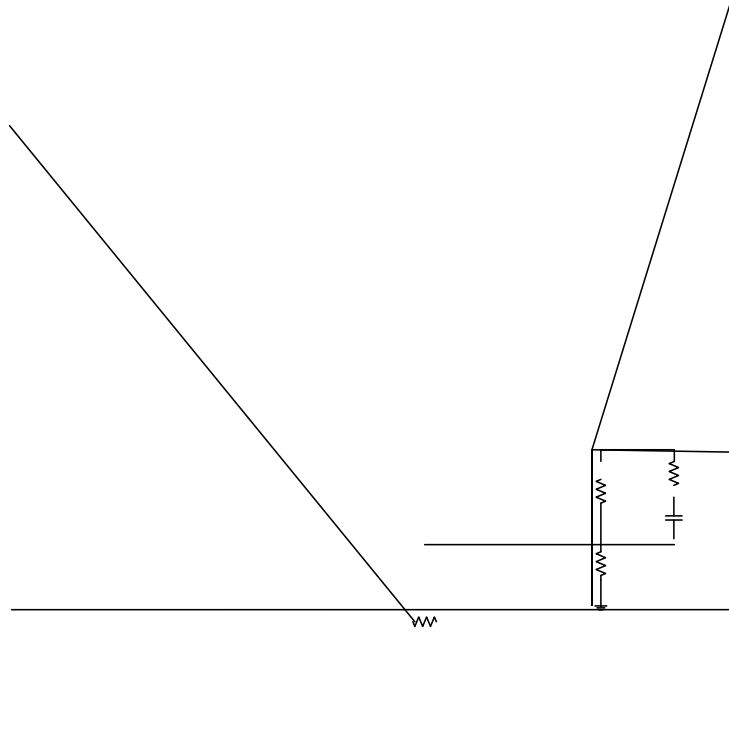

	_____

	<p style="text-align: center;">_____</p> <p style="text-align: center;">_____</p> <p style="text-align: center;">_____</p>
	<p style="text-align: center;">_____</p> <p style="text-align: center;">_____</p> <p style="text-align: center;">_____</p>
	<p style="text-align: center;">_____</p> <p style="text-align: center;">_____</p>

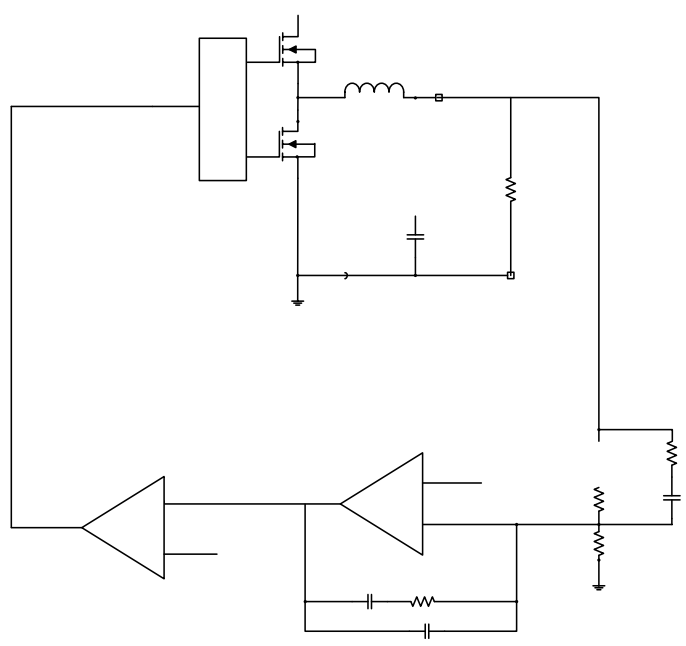

---

---

---



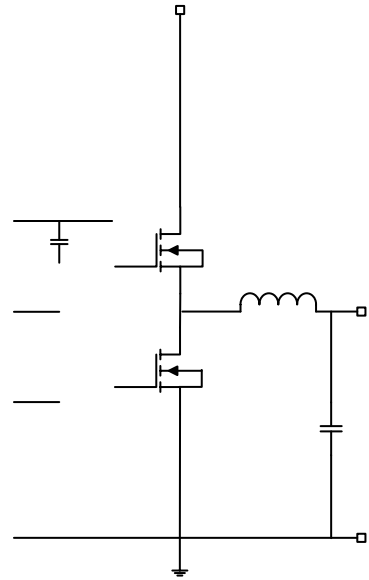



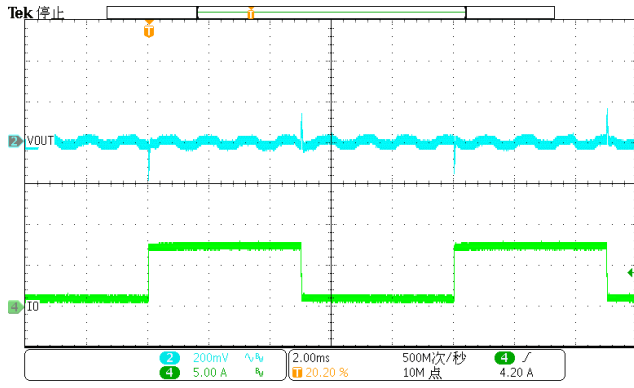

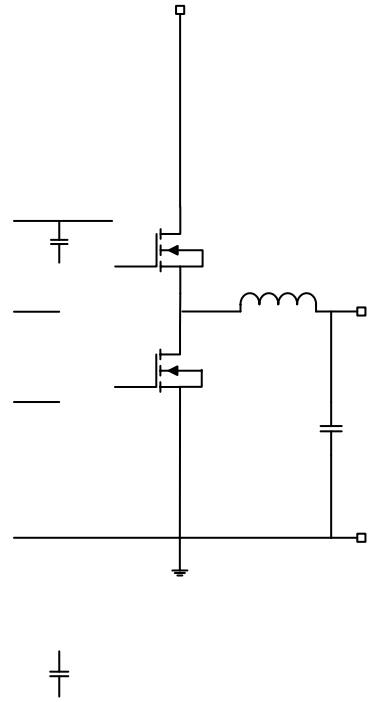

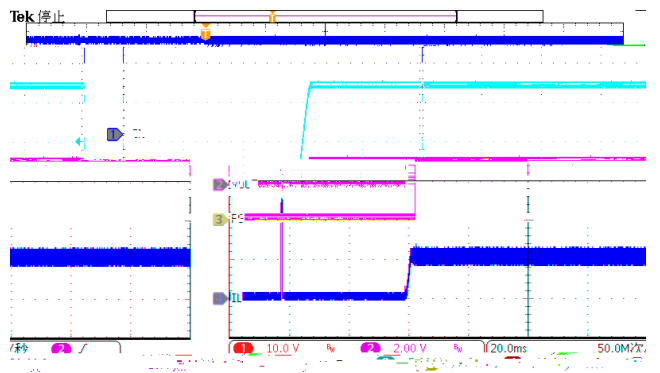
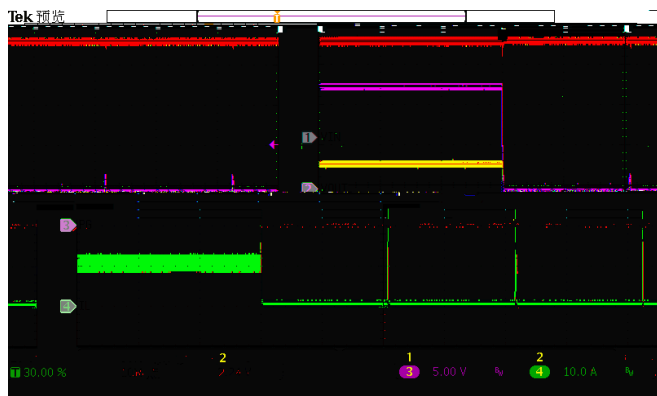
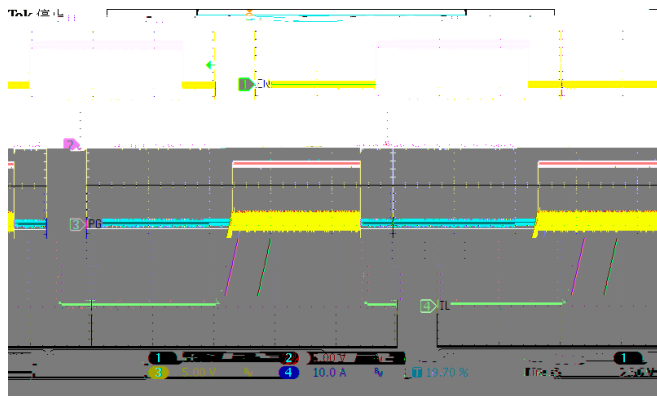
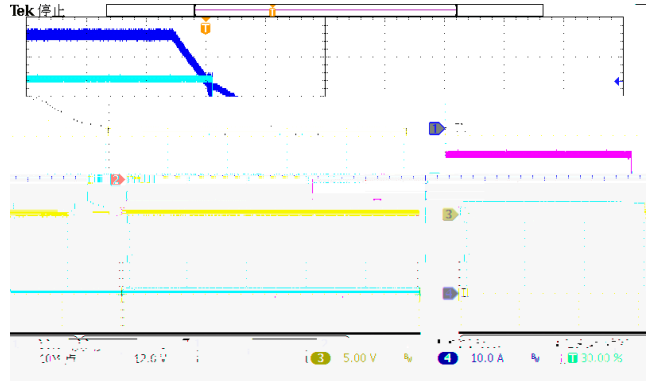
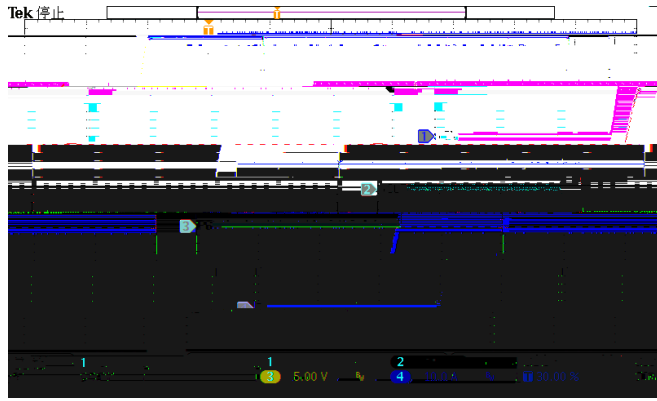

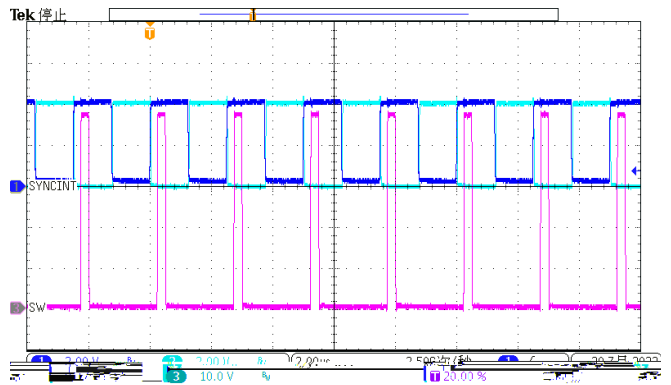
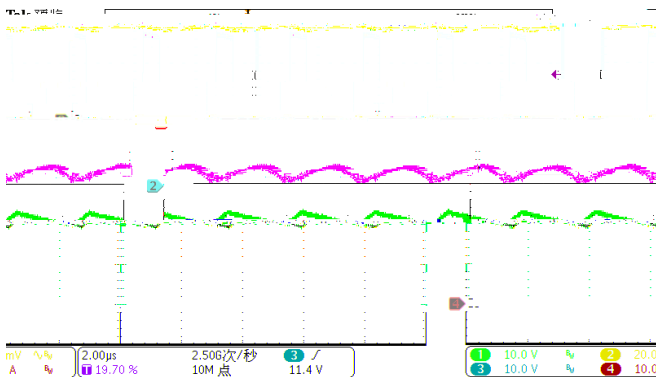
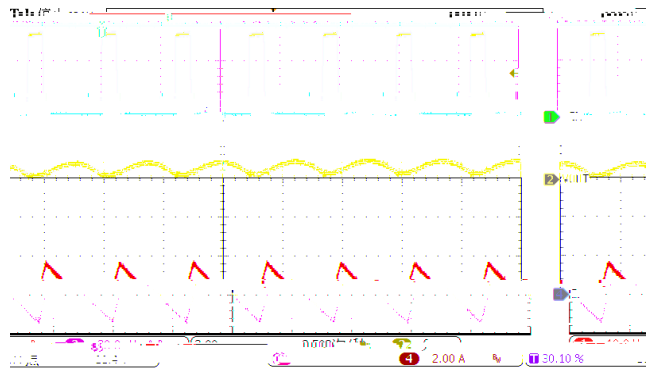
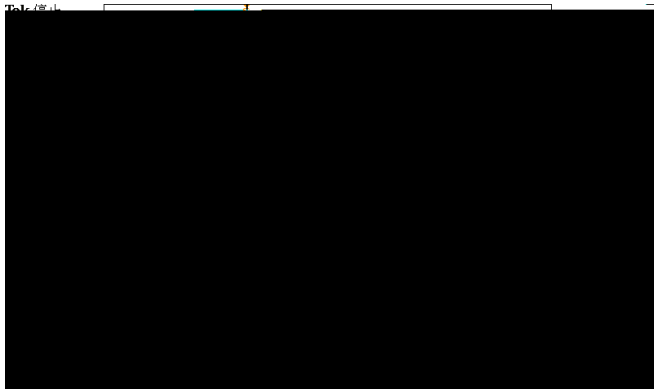
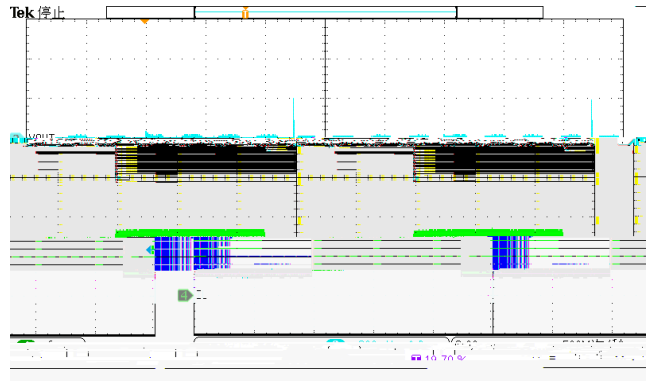
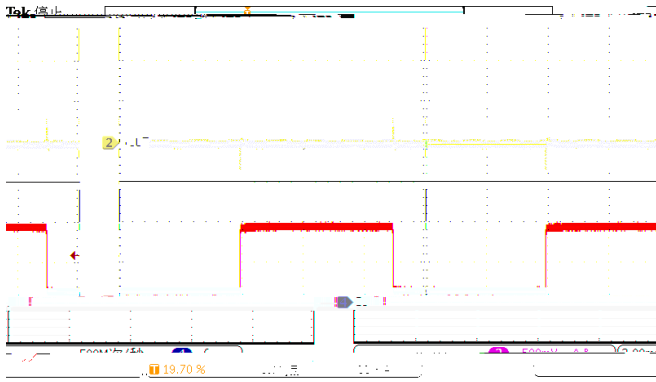
---

Vout	L	COU <sub>T</sub>	R <sub>FB</sub>	R <sub>FB</sub>	R <sub>c</sub>	C <sub>c</sub>	C <sub>c</sub>	R <sub>c</sub>	C <sub>c</sub>
V	. uH	* uF	. K	. K	. K	nF	pF		. nF
V	. uH	* uF	K	. K	K	. nF	pF		. nF
V	. uH	* uF	. K	. K	. K	. nF	pF		pF

