I_{Q_Charge} On MAX and MIN

--	--	--	--	--	--

(1)
(2)

--	--	--	--	--

V _(ANODE)				
V _(ANODE POR)	VANODE POR Rising threshold VANODE POR Falling threshold			
I _{SHDN}		V _{EN} = 0V		
I _{Q_Charge Off}				
I _{Q_Charge On}				

ENABLE

V _{EN_H}	Enable input high threshold			
V _{EN_L}	Enable input low threshold			
V _{EN_HYS}	Enable Hysteresis			



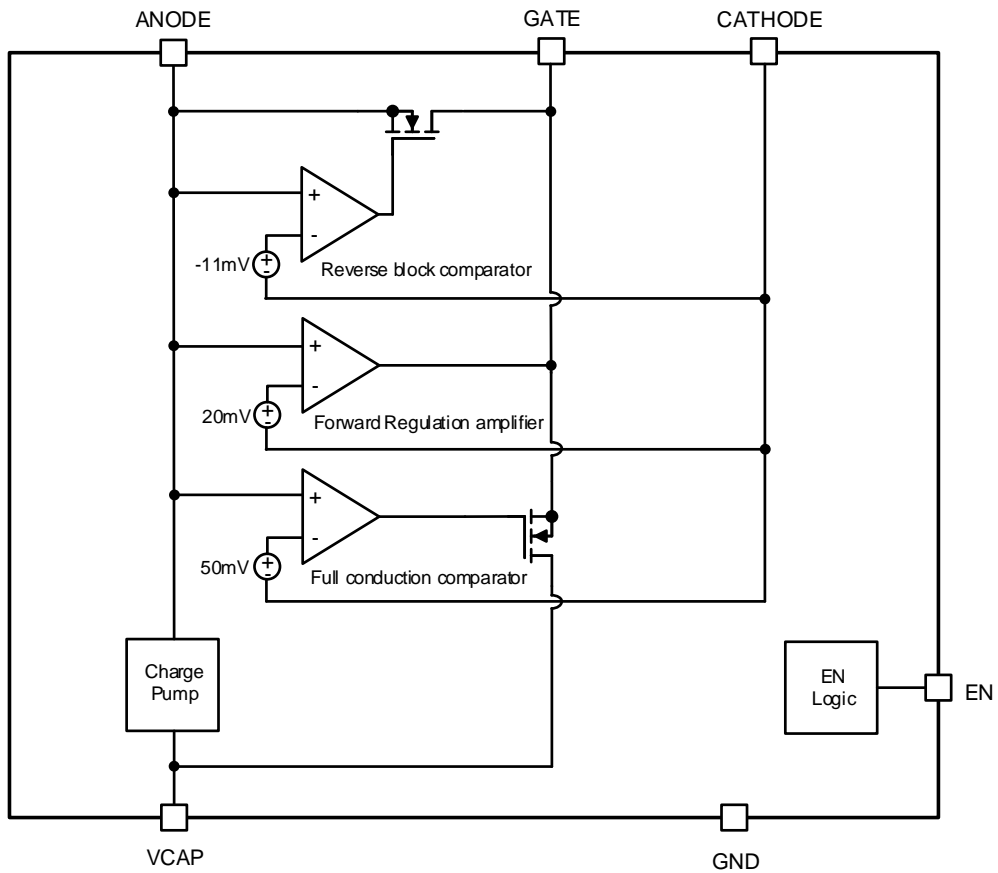

Overview

protection circuit or be used in a . This easy to use ideal diode controller operates in polarity conjunction with an external N-channel MOSFET to replace other reverse polarity schemes such as a P-channel MOSFET or a Schottky diode.

Input Voltage

Enable

Charge Pump

Gate Driver and Conduction Mode



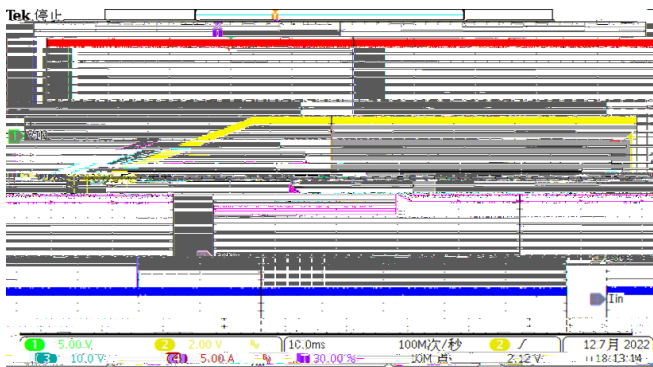
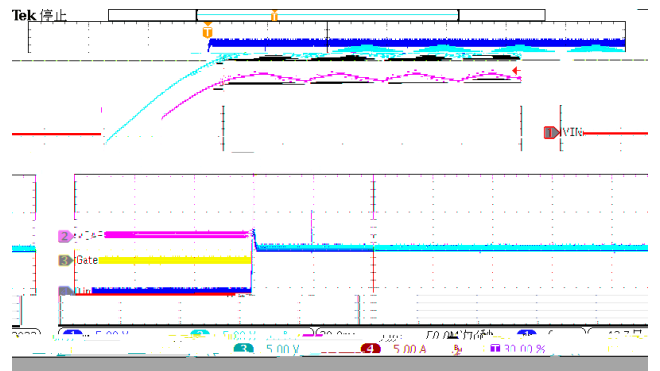
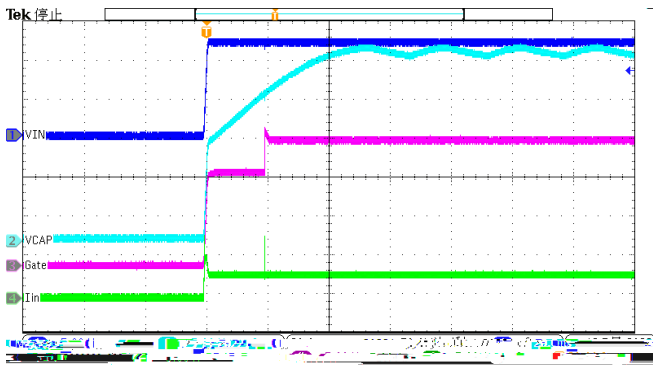
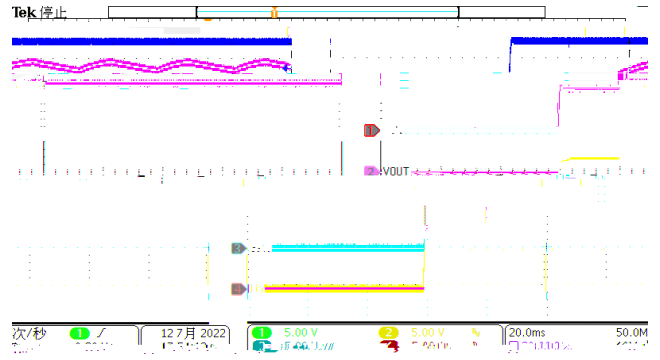
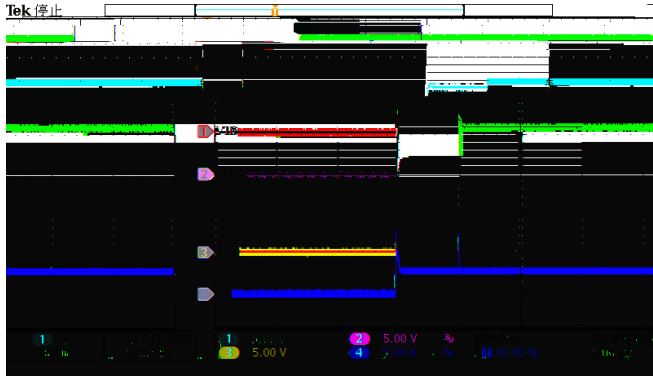

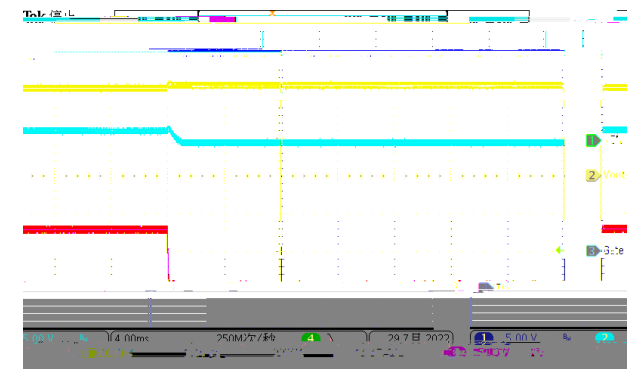
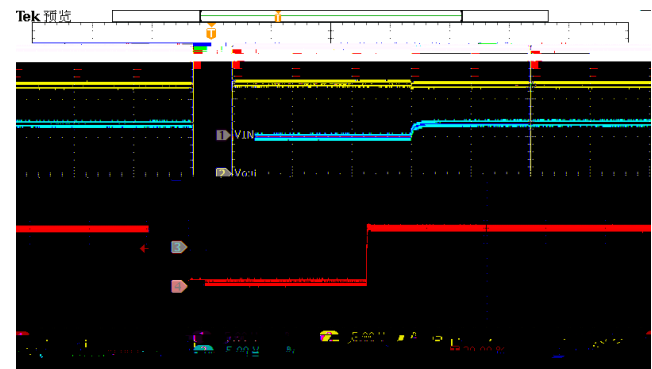
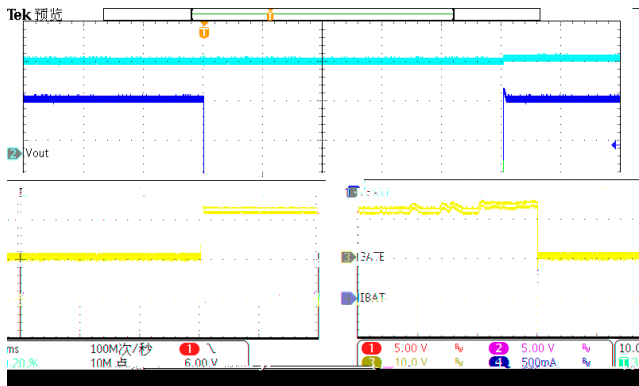
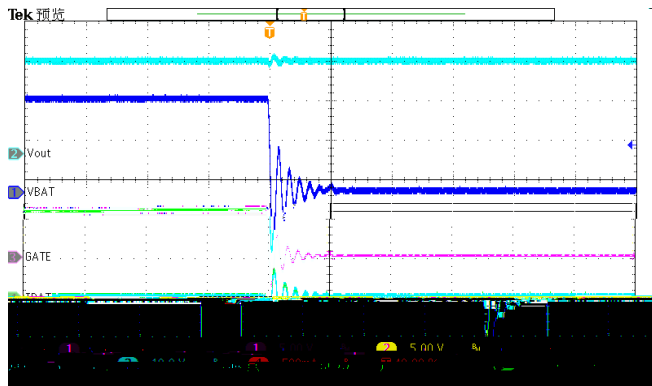
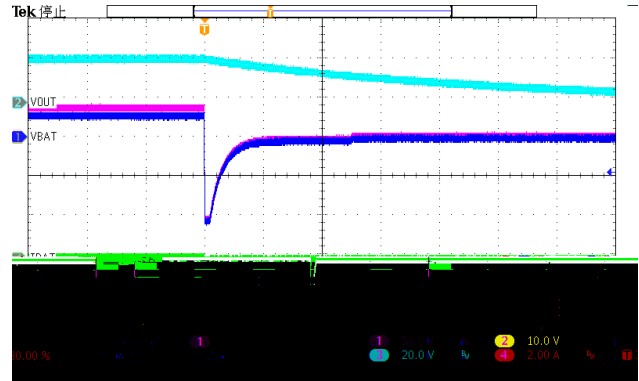
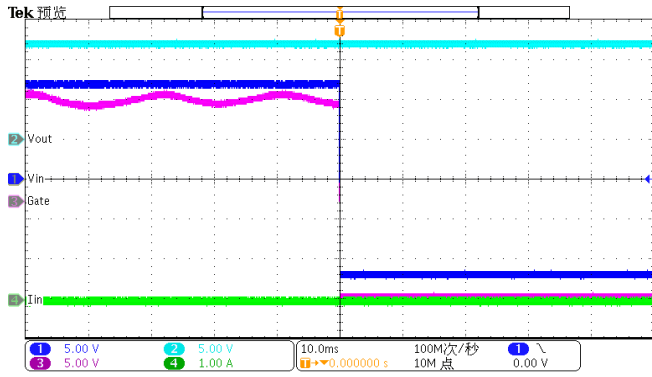

Typical Application- Redundant Power

